

All power tools can be dangerous if both general and tool specific safety instructions are not followed carefully. General safety instructions apply to all power tools, both corded and cordless.

Start with a Safe Work Area



Keep your work area clean and well lit. Cluttered benches and dark areas invite accidents.



Do not operate power tools in explosive atmospheres, near flammable liquids, gases, or dust. Power tools create sparks, which may ignite the dust or fumes.

- Keep bystanders, children, and visitors away when using a power tool. Distractions can cause you to lose control.



Electricity can be Dangerous

Grounded tools (three pronged cords) must be plugged into a properly grounded installed outlet. Never remove or cut off the grounding prong or modify the plug in any way. Do not use any adapter plugs.



Double Insulated tools have a polarized plug (one blade is wider than the other.) This plug will fit into an outlet only one way. Do not change the plug in any way.



Do not use AC only rated tools with a DC power supply.



Store battery packs away from other metal objects like paper clips, coins, keys, nails, screws, or other small metal objects. These things can make a connection from one terminal to the other, shorting the battery terminals together and causing burns or fire.



- When using a power tool, don't touch grounded surfaces such as pipes, radiators, ranges and refrigerators. There is a higher risk of electric shock if your body is grounded.

GFCI

In damp locations, only plug your tool into a Ground Fault Circuit Interrupter (GFCI). If the work area does not have a permanent GFCI on the outlet, use a plug-in GFCI. Wear rubber gloves and footwear.



Don't use or leave power tools in the rain or wet conditions.



Do not abuse the cord, carry the tool by its cord, or pull the cord to unplug it. Keep the cord away from heat, oil, sharp edges or moving parts. Replace damaged cords immediately.



Always hold the tool by the insulated gripping surfaces. Contact with hidden wiring or its own cord will make exposed metal parts of the tool "live" and shock the operator.

Rules about Extension Cords

- When using a power tool outside, use an extension cord marked for outdoor use with "W-A" or "W". These cords are made for outdoor use.
- Extension cords with 3-prong grounding plugs must be plugged into 3-prong outlets when using grounded tools.
- Replace damaged or worn cords immediately.

Amps

The wire gauge and length of the extension cord must be able to handle the amps of the tool. Find the Amps (A) on the tool's nameplate and use the chart to determine the necessary wire gauge for your extension cord length.

Nameplate Amps	Extension Cord Gauge			
	Cord Length in Feet			
	25'	50'	100'	150'
0-6	18	16	16	14
6-10	18	16	14	12
10-12	16	16	14	12
12-16	14	12	Not Recommended	

Good Personal Safety is a Must

Following good safety practices when using all power tools is a must. Make a habit of including safety in all of your activities.



Always read and understand the tool's operator's manual, tool markings and the instructions packaged with the accessory before starting any work.

- Stay alert, watch what you are doing and use common sense when using a power tool.



Do not use tools when you are tired or under the influence of drugs, alcohol, or medication.

- Dress right. Do not wear gloves, loose clothes or jewelry. Contain long hair. Loose clothes, gloves, jewelry, or long hair can be caught in moving parts.
- Keep handles dry, clean and free from oil and grease.
- Be sure the power tool's switch is OFF before plugging it in or inserting a battery pack. Do not carry tools with your finger on the switch.



Remove adjusting keys and wrenches before turning the tool ON.

- Always keep a firm footing when using power tools. Be sure you have balance and control before you start the job.



Use safety equipment. Always wear eye protection. A dust mask, non-skid safety shoes, hard hat, or hearing protection must be used when needed. The reference to “safety goggles” or “safety glasses” in product specific sections provides potential options - always refer to the tool’s operator’s manual for the specific eye protection recommended, which should be marked as complying with current national standards.

- Unplug tool/remove battery before changing accessories.



Keep hands away from rotating or moving parts.

Do the Job Safely

- Use the power tool accessories only for the jobs for which they were designed.



Secure and support the workpiece. Use clamps and a stable work surface. Do not hold the work by hand or against your body.

- Keep guards in place and working properly.
- Do not force the tool. Use the right tool for your job. It will do the job better and safer.
- Use only accessories recommended by the tool manufacturer. Accessories that may be suitable for one tool may become hazardous when used on another tool.



Do not touch the drill bit, blade, cutter or the workpiece immediately after operation; they may be very hot and may burn you.

- If a method of dust collection is available with the power tool, it should be used to reduce the risk of dust-related hazards.

Maintenance Keeps Tools Working Safely and Effectively

- Do not use a tool if the switch does not turn it on and off. It must be repaired.



Look at the tool before using it. Are moving parts misaligned or binding? Is anything broken? Damaged tools must be fixed before using them. Develop a maintenance schedule for your tool.

- Maintain accessories carefully. Keep blades and bits sharp and clean.
- Take your tool to be serviced by qualified repair people. Service or maintenance performed by unqualified personnel could result in a risk of injury. For example: internal wires may be misplaced or pinched, safety guard return springs may be improperly mounted.
- When servicing a tool, use only identical replacement parts. Follow instructions regarding maintenance in the tool’s operator’s manual. Use of unauthorized parts or failure to follow the maintenance instructions may create a risk of electric shock or injury.
- Clean and lubricate a tool only as directed in its operator’s manuals. Certain cleaning agents such as gasoline, carbon tetrachloride, ammonia, etc. may damage plastic parts.
- Maintain labels and nameplates. These carry important information. If unreadable or missing, contact the manufacturer for a replacement.

When Done, Store the Tools out of Harm’s Way



To avoid accidental starting, unplug the cord, remove batteries or lock off the switch when the tool is not being used, when changing accessories, and when adjusting or cleaning tools.

- Keep tools out of the reach of children and people unfamiliar with the tools.

Grinders (Portable and Bench)

Grinders and sanders are highly versatile tools capable of accepting a variety of attachments and accessories that allow the tool to be used for grinding, sanding, polishing, wire brushing or cutting-off operations. The proper guarding and safety devices must be used with the accessories (e.g., the proper type of guard used with a certain grinding wheel).

Good Personal Safety is a Must

Following good safety practices when using a grinder is a must. Make a habit of including safety in all your activities.



Always read and understand the tool's operator's manual, tool markings and the instructions packaged with the accessory before starting any work.



Always wear safety goggles or safety glasses with side shields complying with current national standards, and a full face shield when needed.



Use the appropriate mask or respirator in dusty work conditions.



Wear proper hearing protection, as needed.



Wear gloves and a shop apron capable of stopping small abrasive or workpiece fragments.

- Dress right. Do not wear loose clothes or jewelry. Contain long hair. Loose clothes, jewelry, or long hair can be caught in moving parts.
- Crowded, cluttered work areas that can cause tripping or loss of balance are particularly dangerous.



Do not operate the power tool near flammable materials. Sparks could ignite these materials.

Choose the Right Tool and Accessory

Choosing the correct tool and the proper accessory for your application can help to reduce the risk of serious injury. When used according to the manufacturer's instructions, the proper tool and accessory will do the job safer and faster.



When it is recommended to use a guard with a wire brush, do not allow the wire brush to rub against the guard. The wire wheel or brush may expand in diameter due to work load and spinning.

- Wheels must be used only for their recommended jobs. For example, do not grind with the side of a cut-off wheel. It will shatter.
- The outside diameter and the thickness of your accessory must be within the capacity rating of your power tool (e.g., don't use an 8" wheel on a 7" grinder). Incorrectly sized accessories cannot be adequately guarded or controlled.

- Use the correct accessory for your tool. Check this carefully: Does it fit the spindle of the power tool. Be careful not to over-tighten the spindle nut. Too much pressure will deform the flanges and stress the wheel. Accessories with arbor holes that do not match the tool will wobble, vibrate excessively and may cause loss of control.
- Always use undamaged wheel flanges that are the correct size and shape to properly support your accessory.

RPM

Make sure the speed marked on the accessory is at least as high as the no load RPM marked on the tool. Accessories running faster than their rated speed can fly apart.



Do not use accessories that require liquid coolant, unless your tool has been specifically designed for operations with liquid coolant. Using water or other liquid coolants may result in electrocution or shock.

Portable Grinders:

- Determine the type of tool needed for the job. Portable grinders come in various types, such as: "straight" grinders, "vertical" grinders or "angle" grinders.
- Do not use a grinder that is too heavy for you to easily control.
- When sanding, do not use excessively oversized sanding disc paper. Follow tool manufacturer's recommendations when selecting sanding paper.

Know your Workpiece

- Avoid working on small pieces of material which can't be properly secured. Injury could result from small pieces being thrown by the spinning accessory.

Portable Grinders:



Know what is behind a workpiece before you do the job. Do not cut into existing walls or other blind areas where electrical wiring, water, or gas pipes may exist. If this situation is unavoidable, disconnect all fuses/circuit breakers, and shut off any water and gas lines feeding this work site.

Before Grinding...

Before working with a grinder, make sure the tool and its accessories are in proper working order. Failure to do so may increase your risk of injury.

- Handle accessories carefully to prevent damage or cracking. Do not use a damaged accessory.
- Before each use, inspect
 - abrasive wheels for chips and cracks
 - backing pad for cracks, tear or excess wear
 - wire brush for loose or cracked wires.



- Test grinding wheels before mounting. Tap the wheel lightly with a nonmetallic implement such as the handle of a screwdriver. If it produces a ringing sound, it is in good condition. If it sounds dull, replace the wheel. **DO NOT USE A CRACKED WHEEL.**



- Tuck away or trim any loose portion of a polishing bonnet or its attachment strings.



After inspecting and installing an accessory, position yourself and bystanders away from the rotating accessory and run the power tool at maximum no load speed for one minute. Damaged accessories will normally break apart during this test time.

- Keep bystanders a safe distance away from the work area. Anyone entering the work area must wear personal protective equipment. Pieces of a workpiece or a broken accessory may fly away.
- Be sure the tool switch works properly. Do not use a tool if the switch does not turn it off when returned to the off position.

Portable Grinders:

- Be sure the guard is securely attached to the tool and positioned for maximum safety, so the least amount of wheel is exposed toward the operator during use.
- Position the cord away from the spinning accessory. If you lose control, the cord may be cut or snagged and your hand or arm may be pulled into the spinning accessory.



- Bench grinder wheels should be trued and dressed when worn out of round, or the surface face is clogged or worn smooth. This provides a clean sharp grinding surface and rebalancing of the wheel.



New bench grinder wheels should be balanced by dressing and truing to eliminate vibration and possible mishap. Check your operator's manual. Don't operate a grinder unless you are certain the grinder, its base and/or stand are securely mounted.

While Grinding...



Concentrate on what you are doing and be aware of kickback (a sudden reaction to a pinched or snagged accessory). Pinching or snagging causes rapid stalling of the rotating accessory. This forces the uncontrolled power tool in the direction opposite the accessory's rotation at the point of binding. It can also cause an uncontrolled workpiece to be thrown.

- For example, when using a portable grinder, if an abrasive wheel is snagged or pinched by the workpiece, the edge of the wheel entering the pinch point can dig into the surface of the material causing the wheel to climb or kick out of the workpiece. The wheel may either jump toward or away from the operator, depending on direction of the wheel's movement at the point of pinching. Abrasive wheels may also break under these conditions.
- Kickback is the result of power tool misuse and/or incorrect operating procedures or conditions, and can be avoided by taking proper precautions.



Never place your hand near the rotating accessory. The tool may kick back.

- Use special care when working on corners, sharp edges, etc. Avoid bouncing and snagging the accessory. Corners, sharp edges or bouncing have a tendency to snag the rotating accessory and cause loss of control or kickback.



Do not attach a saw chain, woodcarving blade, or toothed saw blade. Grinders are not designed for these types of blades.

- Do not "jam" a cut-off wheel or apply excessive pressure. Do not attempt to make an excessive depth of cut.



When using wire brushes, wire bristles are thrown during ordinary operation. Do not over-stress the wires by applying excessive load to the brush.

- When stopping a cut, switch off the tool and hold the tool motionless until the wheel comes to a complete stop. Never attempt to remove the cutoff wheel from the cut while the wheel is in motion.
- Do not restart the cut in the workpiece. Let the wheel reach full speed and then carefully re-enter the cut.

Portable Grinders:

- Maintain a firm grip on the power tool and position your body and arms to allow you to resist kickback forces. Always use an auxiliary (side) handle, if provided, for maximum control over kickback or a torque reaction during start-up. The operator can control torque reactions or kickback forces, if proper precautions are taken.
- Do not position your body in the area where the power tool will move if kickback occurs. Kickback will propel the tool in the direction opposite to the wheel's movement at the point of snagging.
- Support panels or any oversized workpiece to minimize the risk of wheel pinching and kickback. Large workpieces tend to sag under their own weight. Supports must be placed under the workpiece near the line of cut and near the edge of the workpiece on both sides of the wheel.
- When it is recommended to use a guard with a wire brush, do not allow the wire brush to rub against the guard. The wire wheel or brush may expand in diameter due to work load and spinning.

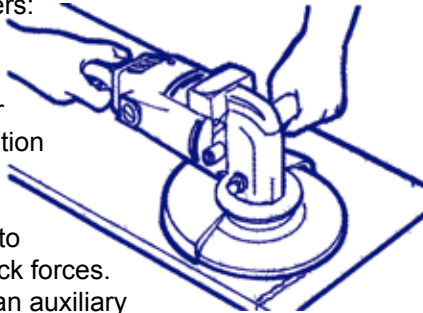

Bench Grinders:

- On bench grinders, tool rests and spark guards are adjustable to compensate for wheel wear. They must be reset when a new wheel is installed or after a wheel has been worn or dressed. The distance between the spark guard and the wheel should be within 1/16". The tool rest should be slightly below the center of the wheel with 1/8" or less clearance from the wheel. This prevents accidental jamming between tool rest and the wheel.

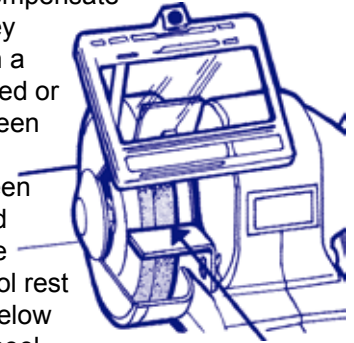

When Done...



Unplug, clean and store the tool in a safe, dry place after use.

Never lay the power tool down until the accessory has come to a complete stop. The spinning accessory may grab the surface and pull the power tool out of your control.

- Do not run the power tool while carrying it at your side. Accidental contact with the spinning accessory could snag your clothing, pulling the accessory into your body.



Regularly clean the power tool's air vents. The motor's fan will draw the dust inside the housing and excessive accumulation of powdered metal may cause electrical hazards.

- Store accessories with care. Do not drop them or subject them to excessive heat, cold or humidity.